



Tyco Electronics Corporation
300 Constitution Drive
Menlo Park, CA 94025 USA

Raychem

Specification
This Issue:
Date:
Replaces:

RT-1050/3
Issue 4
March 3, 1997
Issue 3

Thermofit[®] Adhesive and Sealant
Thermofit S-1048

Thermofit S-1048 thermoplastic adhesive is a special high performance material which exceeds the high and low temperature properties of many other thermoplastic adhesives. This material was developed for precoating the bonding areas of Thermofit heat-shrinkable parts. It is supplied in tape form (approximately 1" wide and .018" thick) and in other forms.* The adhesive is tough and flexible and exhibits very low flow in the melt. It bonds well to polymeric materials such as Raychem's polyolefins and neoprene, and to metals such as steel and aluminum.

PROPERTY	UNIT	REQUIREMENT	METHOD OF TEST
PHYSICAL			
Visual		Pass	Section 4.3.1.1
Specific Gravity		1.0 ± .05	Section 4.3.1.2 ASTM D 792
Softening Point	C	165 ± 10	Section 4.3.1.5 ASTM E 28 Note 1
Low Temperature Flexibility 4 hours at -55° C (-67° F)	C	No cracking	Note 2
Blocking Cohesive @ 65° C (149° F) 1 X 3 inch tape specimens 1 pound weight		Free to first degree	4.3.1.8 ASTM D 1146
Adhesive Peel	Pounds/inch width		Note 3
Polyethylene to Polyethylene		15 minimum	
Polyethylene to Aluminum		15 minimum	
Polyethylene to Steel		15 minimum	
Neoprene to Neoprene		15 minimum	
CHEMICAL			
Water Absorption, 24 hours at 23° C 1 X 3 inch tape specimens	Percent	2.0 maximum	Section 4.3.2.1 ASTM D 570
Corrosive Effect 16 hours at 121° C (250° F)		Non-Corrosive	Section 4.3.2.2 ASTM D 2671 Method B
Fungus Resistance 1 X 2 inch tape specimens		Rating of 1 or less	Section 4.3.2.5 ASTM G 21

Solvent and Fluid Resistance 24 hours at 23° C (73° F) 1 X 3 inch tape specimens Cleaning Compound (PC 437) JP-4 Fuel (MIL-T-5624) Hydraulic Fluid (MIL-H-5606) Lube Oil (Mil-L-7808) Lube Oil (Mil-L-23699) ASTM Reference Fuel B	percent percent percent percent percent percent	5 maximum 30 maximum 20 maximum 5 maximum 5 maximum 30 maximum	ASTM D 543 Note 4
ELECTRICAL Volume Resistivity 6 X 6 X 0.050-inch specimen Dielectric Strength 6 X 6 X 0.050-inch specimen	ohm-cm volts/mil	10 ¹⁰ min 500 min	Section 4.3.3.1 ASTM D 257 Section 4.3.3.2 ASTM D 149

Acceptance Tests: Visual, Softening Point, Adhesive Peel (Steel)

* Qualification of tape form qualifies all forms.

NOTE 1 SOFTENING POINT

Dry S-1048 tape overnight at room temperature in a vacuum chamber to reduce void formation during pressing. Lay a cross hatch of tape strips in a mold window 2" x 2" x 5/32". Place Teflon* coated glass cloth between the backing plate and the mold, insert in a press at 150°C at minimum contact pressure for a 1 minute preheat, then increase the pressure to 20,000 lbs. ram force for 1 additional minute. Transfer to a cold press at 20,000 lbs. ram force until cool. Remove and inspect the slab. If substantially void free, punch two 5/8" diameter disks and two 25/32" diameter disks. Fit one disk of each size in a shouldered brass ring, then insert one of the brass rings in a 2" diameter support ring. Place the assembly, bottom down, on a 0.060" (1/16") backing plate covered with a sheet of Teflon coated glass cloth. Put a second sheet of Teflon coated glass cloth and a second backing plate (an 8" x 8" x 1/16" backing plate should weigh about 485 gms.) on top, and place the whole assembly in a press heated to 170 ± 5°C. Raise the lower platen until the top backing plate is near but not touching the upper platen. Heat transfer should be from the bottom platen up through the sample. The upper backing plate is brought near the upper platen only to reduce heat loss. No pressure, other than the weight of the backing plate, should be applied to the top of the sample. Allow 4 minutes for the sample to heat through and consolidate, then remove the assembly and cool on a cold surface. Remove the backing plates and Teflon coated glass cloth. The upper surface should have deformed and flowed noticeably over the support ring. Loosen the flash on the support ring and press the shouldered brass ring out of the support ring. Trim the excess flash off with scissors. The upper surface of the S-1048 will now be .020 - .030" above the surface of the brass ring (the thickness of the molding flash). Using a very hot blade, quickly trim it flush, preferably in a single rapid sweep. Both bottom and top surfaces of the S-1048 should now be flush with the brass ring, and the sample should be completely consolidated and void free. Prepare the second sample in the same way. Measure the softening point in accordance with ASTM E 28.

NOTE 2 LOW TEMPERATURE FLEXIBILITY

Cut 3 strips, 1/4" x 6", from a length of S-1048 tape. Place the strips and a 1/4" diameter mandrel in a -55 ± 2°C cold chamber for 4 hours. While still in the chamber wrap the strips 360° around the mandrel in approximately 2 seconds.

NOTE 3 ADHESIVE PEEL

A) Substrates

Material	Use
Polyethylene	Thermofit RNF-100
Neoprene	Thermofit NT-FR
Aluminum	2024-T3 or equivalent
Steel	ASA-B36.10-1939

*trademark of Du Pont

B) Heat Shrinkable Tubing to Heat Shrinkable Tubing

Recover a 6-inch length of the specified heat shrinkable tubing on a glass-laminated plastic or a metal tube 1 inch in diameter. Apply heat with a Thermofit 500A Thermogun equipped with a TG 13 reflector and operating at 288 to 343°C (550 to 650°F). Cool the recovered tubing to room temperature. After cooling, lightly abrade the outside of the recovered tubing and the insides of three 1-1/2 inch lengths of the specified 1-1/2 inch diameter expanded tubing with No. 320 emery cloth. Wipe with a clean cloth or paper towel wet with methyl ethyl ketone and allow sufficient time to dry. Spiral wrap the adhesive tape, with a 50% overlap to produce a double thickness of adhesive, over the recovered tubing. Place a strip of 3/4-inch-wide masking tape lengthwise over the adhesive tape to hold it in place and to provide unbonded ends to insert into tensile tester. (Figure A).

Place three 1-1/2 inch lengths of the tubing, abraded on the inside, over the adhesive, as shown in Figure A, and recover as described above. Continue heating for 30 seconds after the tubing has recovered. Place the assembly in an oven for 10 minutes at $150 \pm 3^\circ\text{C}$ ($302 \pm 5^\circ\text{F}$) to assure uniform heating. Cool to room temperature, and cut along one edge of the masking tape to remove the bonded assembly from the mandrel (Figure B). Cut a specimen 1 inch wide (Figure C) from the center of each double thickness.

Insert the unbonded ends of each specimen in the jaws of a tensile tester operating at a jaw separation speed of 2 inches per minute. Make readings of peel strength at every 1/2 inch of jaw separation after 1 inch initial separation. The average of five readings shall define peel strength.

C) Heat Shrinkable Tubing to Aluminum and Steel

Abrade an 6-inch length of 1-inch diameter aluminum pipe (2024 T-3 or equivalent) or steel pipe, (ASA-B36.10-1939 or equivalent) with No. 320 emery cloth and wipe with a clean cloth or paper towel wet with methyl ethyl ketone. Spiral wrap the adhesive tape on the pipe, with a 50% overlap to produce a double thickness of adhesive. Place a strip of 3/4-inch-wide masking tape lengthwise over the adhesive to hold it in place and to provide unbonded ends to insert into tensile tester. (Figure D)

Abrade, clean, recover and oven-heat three 1-1/2-inch lengths of 1-1/2 inch diameter RNF-100 as described in Section B above. After cooling to room temperature, cut tubing into 1-inch wide sections (Figure D). Cut each specimen along the edge of the masking tape to free unbonded ends of the tubing.

Place the specimen in a tensile testing machine, with the specimen around the positioning mandrel and the free end of the specimen inserted into the tensile testing machine jaw. (Figure E) Construct the holding fixture so that the yoke is free to rotate during testing. Test with a jaw-separation speed of 2 inches per minute. Take readings of peel strength at every 1/2 inch of jaw separation after 1 inch initial separation. The average of five readings shall define peel strength.

NOTE 4 SOLVENT/FLUID RESISTANCE

Immerse three weighed specimens in each of the fluids specified. The volume of the fluids shall be not less than 20 times that of the specimens. After the immersion, lightly wipe the specimens and air dry for 30 to 60 minutes at room temperature. Reweigh the specimens and calculate the percent weight uptake.

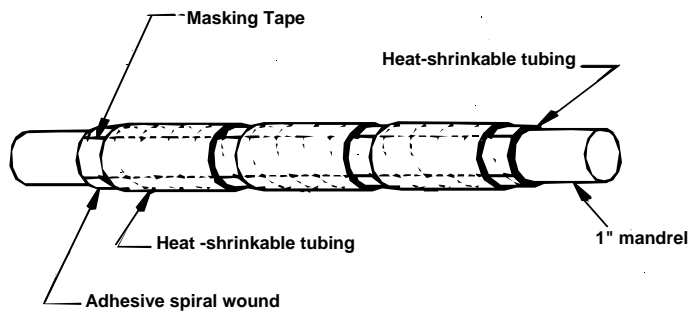

Figure A. Mandrel Assembly

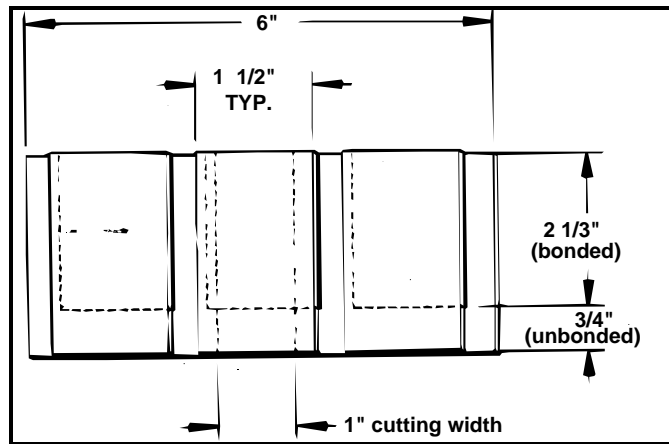

Figure B. Slab Specimen

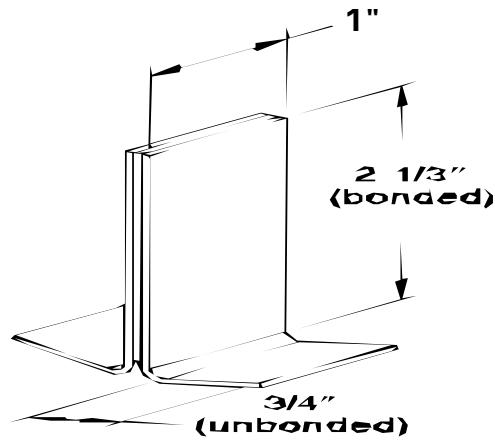

Figure C. Peel Strength Specimen

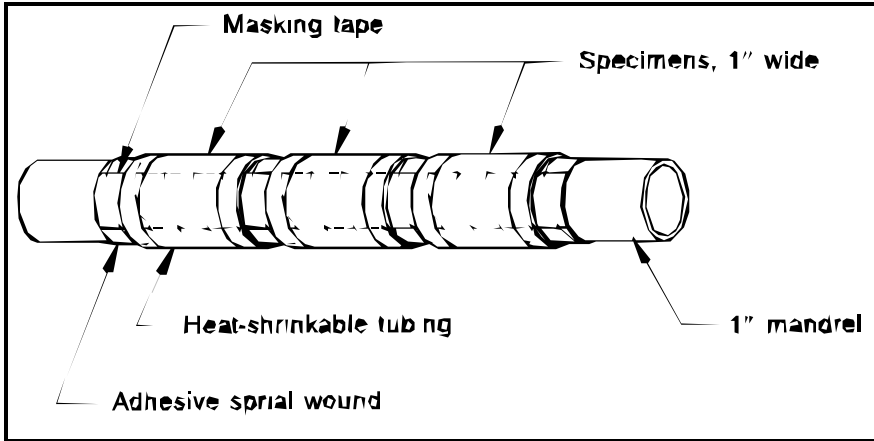

Figure D. Peel Specimen Preparation

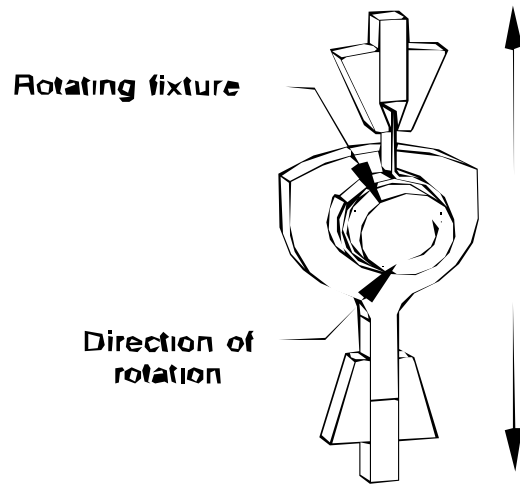

Figure E. Peel Specimen in Tensile Test